

AL08 - Development and Application of Intelligent Control System of Crust Breaker in Aluminum Reduction Cell

Qing Wei¹, Zhuan Song², Jun Wu³, Xu Yang⁴ and Caiqun Zhou⁵

1. Senior Engineer

2. Engineer

3. Professor, vice director

4. Engineer

5. Engineer

Zhengzhou Non-ferrous Metals Research Institute Co. Ltd of CHALCO, Zhengzhou, China

Corresponding author: zyy_songzhuan@rilm.com.cn

Abstract

In the production process of aluminum electrolysis, the chisel of the crust breaker occasionally become sticky and blocking, which leads to the failure of crust breaking and the feed hole blocking. Hence, to maintain the stable operation and the optimization of technical indicators, more efforts should be made. To crack the problem, the intelligent control system of crust breaker of the aluminum reduction cell has been developed in Zhengzhou Non-ferrous Metals Research Institute Co, Ltd of CHALCO. The privileged algorithm of correlation analysis of trajectory trend of chisel head is applied in self-optimizing controlling the crust-breaking frequency and breaker depth with the status of the feed opening detected in real time. Consequently, the alumina is added smoothly without feedhole blocking and the sticky hammer head problem. On average, the total anode effect frequency is decreased by 0.3/cell-day. The system plays a positive role in energy saving, reducing labor intensity and improving intelligent control of aluminum electrolysis potlines.

Keywords: Aluminum electrolysis, intelligent crust breaker, energy saving, crust breaker chisel, feedhole blocking.

1. Introduction

With the consumption of materials, aluminum oxide and fluoride in the cell shall be supplemented constantly during production of electrolytic aluminum. Before feeding, the crust surface is often broken by the crust-breaking cylinder to ensure the smooth feeding and promote dissolution of materials. However, due to the viscosity of electrolyte and poor solubility of aluminum oxide, feeding problems such as chisel head blocking and swelling and material blocking often occur during actual production and result in more anode effects, original aluminum degradation and deterioration of key performance indicators (KPIs). At present, the aluminum electrolysis control system has no effective means to monitor the state of feed hole but only keeping it unblocked through manual inspection and treatment, which leads to such problems as high workload and bad working environment. Therefore, it is hard for the enterprise to recruit and retain workers.

To solve the above problems, Zhengzhou Nonferrous Metals Research Institute Co., Ltd. of CHALCO has developed the intelligent control system of crust breaker of the aluminum reduction cell. The system can detect the blocking state of feed hole accurately by tracking the motion trajectory of cylinder, adjust the crust-breaking and feeding strategy dynamically, reduce the blocking of feed hole and bath accumulation on chisel head and greatly reduce the labor intensity.

2. System Composition

The intelligent crust breaker system includes field control equipment and upper computer management system. The field control equipment includes intelligent control box, solenoid valve, sensor and gas circuit elements. The intelligent control box is installed beside each electrolytic cell, which monitors the state of feed hole with sensor, adjusts the crust-breaking strategy according to the state of the feed hole and realizes intelligent crust breaking. The upper computer management system is installed in the workshop office, which receives the data of field control equipment through field bus, analyzes, collates and stores the data and realizes centralized display and management of feed hole state of electrolytic cell in the working area. The system structure is shown in Figure 1.

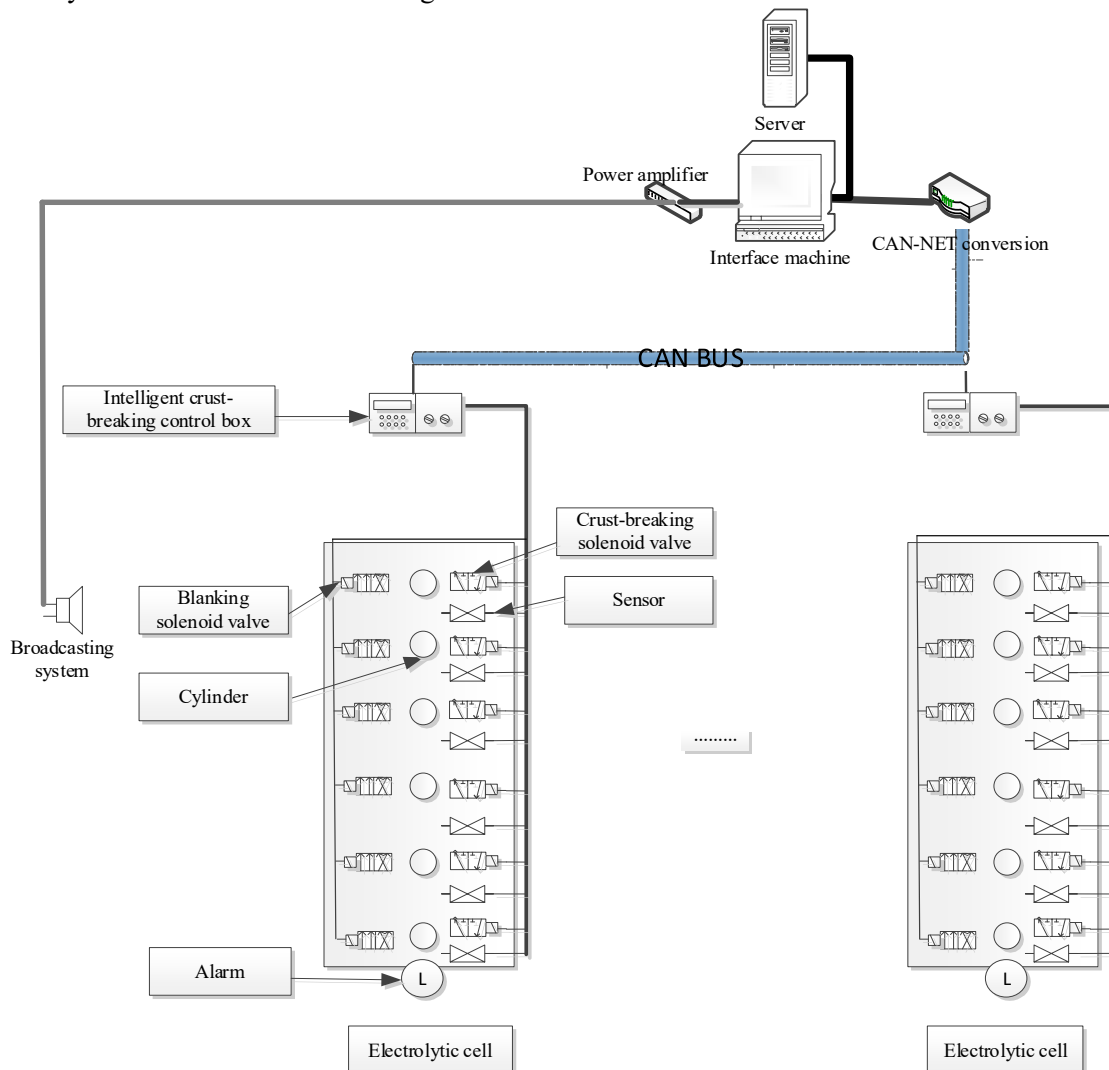

Figure 1. System structure diagram.

2.1. Main Functions of Field Control Equipment

Intelligent control box is the core of field control equipment, the appearance of intelligent control box and field installation situation is shown in Figure 2. It has the following functions:

- (1) The equipment can analyze the action rule of cylinder by tracking the pressure signal of compressed air of each crust-breaking cylinder, and accurately judge the state of feed hole of electrolytic cell.

- (2) The equipment can adjust the crust-breaking and feeding strategy according to the state of feed hole. The equipment can increase the crust-breaking frequency and depth for the feed hole which is blocked frequently; for the feed hole which is prone to having chisel head bath accumulation, the equipment can reduce the crust-breaking frequency and realize self-optimization intelligent control.
- (3) If the feed hole is blocked, the equipment can execute auxiliary through-hole processing program automatically; if the feed hole is still blocked after processing, the system can send alarm signal to prompt manual treatment.
- (4) The state of each feed hole is uploaded to the upper computer through field bus to realize centralized control.
- (5) The equipment has the man-machine interaction function and provided with a full-color lattice screen which is colorful, clear, striking and durable. The keys are capacitive touch keys which have no mechanical contact and have low failure rate.



Figure 2. Appearance of intelligent control box and Field installation situation.

2.2. Main Functions of Upper Computer Management System

The upper computer management system can display the state of feed hole centrally in the whole area and has the following functions:

- 1) Optimal control: The system can adjust the control strategy automatically by analyzing and excavating the data such as crust-breaking times, feeding times and blocking time of each feed hole.
- 2) State display: The system can display the crust-breaking mode and times of each electrolytic cell and the state of feed hole.
- 3) Graph presentation: The curve chart area displays the state of each feed hole in 24 h. The histogram area displays the blocking time and crust-breaking times of each electrolytic cell on duty or the current day.
- 4) Daily report, shift report and statistical report: The system can count the crust-breaking times, blocking times and time of each feed hole of workshop, working area, single cell or some customized cells in a period of time so as to facilitate query and assessment.
- 5) Voice alarm: The system can realize voice broadcast of failure information such as blocking state by connecting with the voice alarm equipment.

3. Principle of Detection of Feed Hole Blocking

The crust-breaking system of aluminum electrolysis cell is composed of cylinder, chisel lever, solenoid valve and compressed air pipeline. During crust breaking, the solenoid valve is powered on, connected with the compressed air and drives the logic reversing valve. After reversing, the compressed air is charged into no-lever cavity, while the lever-cavity discharges the air to realize downward crust-breaking. When the solenoid valve loses power, the logic reversing valve recovers the initial state due to pressure loss, the compressed air is charged into the lever cavity,

and the no-lever cavity discharges the air to retract the chisel head and finishes the crust-breaking action (as shown in Figure 3).

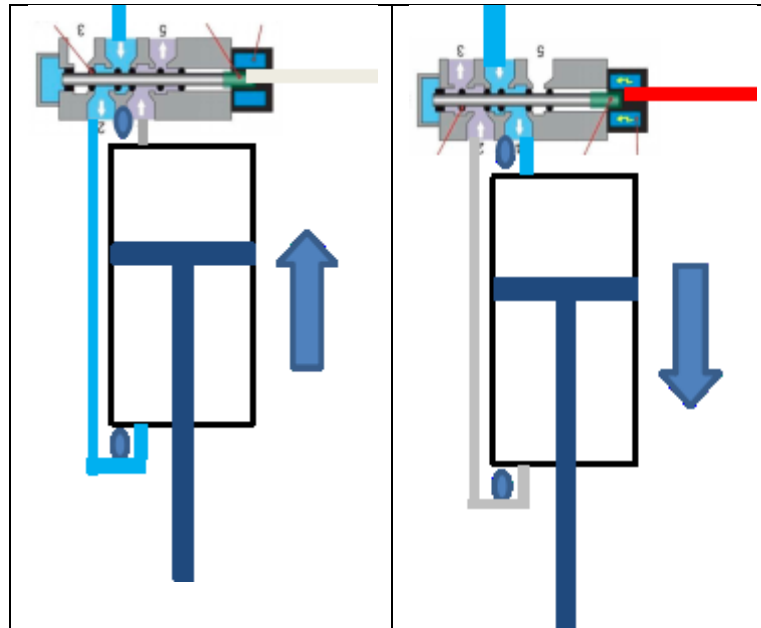

Figure 3. Downward and Upward breaking diagram of cylinder.

Assuming that the cylinder has sufficient compressed air and stable pressure, the air pressure and flow rate in the air inflation pipe conforms to the Bernoulli equation:

$$P_1 + \frac{1}{2} \rho v_1^2 + \rho g h_1 = P_2 + \frac{1}{2} \rho v_2^2 + \rho g h_2 \quad (1)$$

where:

- P Fluid pressure, Pa
- ρ Fluid density, kg/m³
- v Flow rate, m/s
- g Gravitational acceleration, m/s²
- h Height, m

The relationship between fluid pressure and flow rate can be known.

According to the actual situation, the gas flow rate is zero when the cylinder is stationary, and the pressure in air inlet pipe is the air pressure of the system. Whenever the cylinder actions, the Bernoulli equation in a section of parallel air pipe can be simplified as:

$$P_1 = P_2 + \frac{1}{2} \rho v_2^2 \quad (2)$$

where:

P_1 is the air pressure in the air pipe when cylinder is stationary. P_2 is the air pressure in the air pipe when cylinder is activated. The formula shows that the pressure in the air pipe is proportional to the square of the gas flow rate.

Therefore, the gas flow rate in air pipe is:

$$v = \sqrt{\frac{2 \times (P_1 - P_2)}{\rho}} \quad (3)$$

The flow calculation formula of gas charged into the cylinder is:

$$Q = \int_t S \times v dt \tag{4}$$

where:

- Q Flow, m³
- S cross section area, m²
- v flow rate, m/s

After putting into the calculation formula of flow rate,

$$Q = \int_t S \times \sqrt{\frac{2 \times (P_1 - P_2)}{\rho}} dt \tag{5}$$

The cross-section area “S” of air pipe, the gas density “ρ” and the pressure “P₁” in the above formula are measurable constants. The pressure “P₂” only changes with the flow rate when the cylinder is activated. Therefore, when the cylinder is activated, the volume of gas charged into the cylinder cavity can be obtained by continuously measuring the gas pressure and carrying out integral operation on pressure difference.

If the feed hole is unblocked, the crust-breaking action stroke of cylinder is complete, and the whole cavity may be fully charged with compressed air; If the chisel head is clamped or the feed hole is blocked by materials, the action stroke of cylinder is incomplete, the gas volume charged into the cavity will be smaller than the volume of the whole cavity. Therefore, if the feed hole is blocked can be judged according to the gas volume charged into the cylinder. The following figure is the comparison diagram of pressure curves with different crust-breaking strokes.

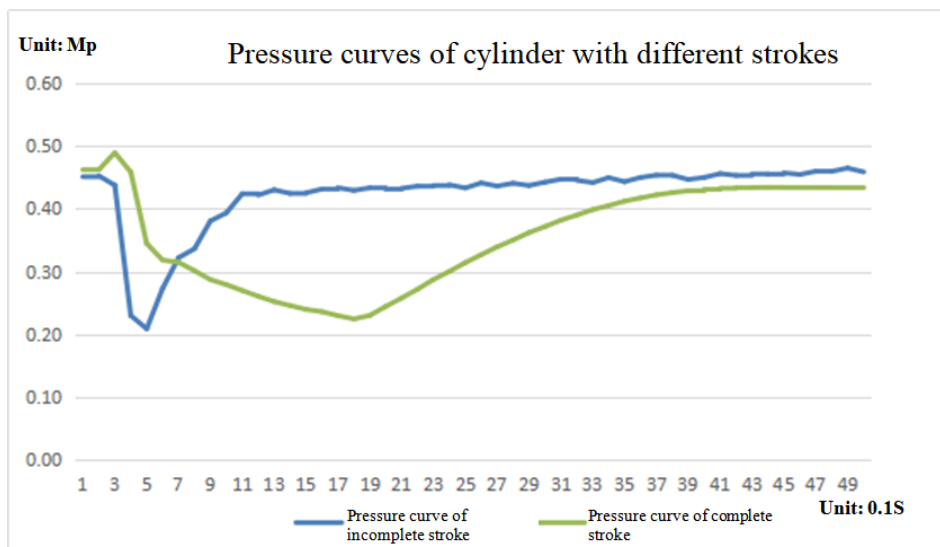

Figure 4. Comparison diagram of pressure curves between complete crust-breaking stroke and incomplete crust-breaking stroke. Unit: Mp = MPa.

As shown in Figure 4, the integrals of complete stroke and incomplete stroke are different obviously, and the experimental data are consistent with the theoretical analysis. The experimental result shows that the method can accurately detect the state of the feed hole. During actual production, the air pressure of system may be changed at any time due to the influence of gas circuit structure and gas operation, and the curve of air pressure is more complicated. After a large number of sample data analysis and long-time experimental verification, the "intelligent association analysis of trajectory trend" is explored and developed. First of all, learning the pressure characteristic curve of the whole action stroke, on the one hand and analyzing the change

trend of air pressure, on the other hand. Second, introducing the supervision neural network model, analyzing, judging and comparing the air pressure operation data of each crust-breaking operation with the experimental result as the basic training sample, then adjusting and training the weight and deviation repeatedly to obtain the best model and finally outputting the result of feed hole state.

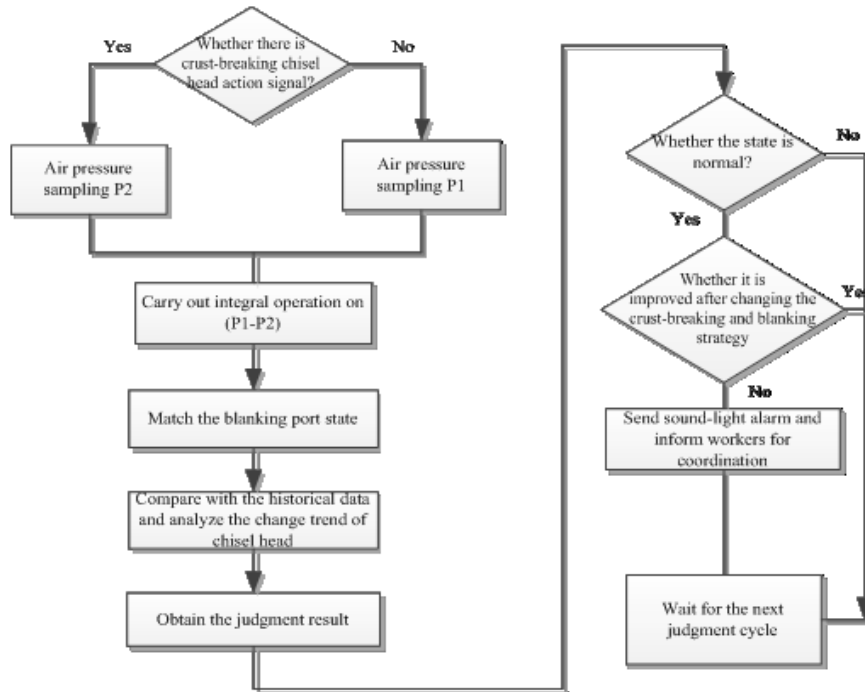

Figure 5. Flow chart of judgment algorithm of feed hole state.

4. Application Effect

The system has been successfully applied to the production line of various aluminum cells. It can judge the state of feed hole accurately, control the chisel head bath accumulation effectively, provide vigorous support for the stable operation of electrolytic cell and is well appraised by all users. The following are the statistical data of five aluminum cells of a 400 kA potline.

4.1. Detection Accuracy of Feed Hole State is Up to 94 %

According to the experimental scheme, specially assigned person shall be arranged for the site tracking and statistics to verify the detection and broadcast accuracy of system.

Table 1. Statistical table of voice broadcast (November 11 to 18) Unit: Times.

Date	11 th		13 th		14 th		15 th		16 th		17 th		18 th		Daily in total	
	Accu rate	Wro ng	Accu rate	Wro ng	Accu rate	Wro ng	Accu rate	Wro ng	Accu rate	Wro ng	Accu rate	Wro ng	Accu rate	Wro ng	Accu rate	Wro ng
43#	1		0		1		1		2		3	1	4		12	1
44#	2		2		2		5		3		4		4		22	0
45#	2	1	3	1	2	1	4		3		1		3		18	0
46#	0		0		0		1		0		1		3		5	3
47#	2		0		2		2		2		2		1		11	0
In total															72	4

The above table shows that the total voice broadcast on the site is 72 times, wherein 68 times are accurate and 4 times are wrong. The alarm accuracy of equipment is 94.4 %.

4.2 Workload for the Chisel Head Bath Accumulation is Reduced by 52 %

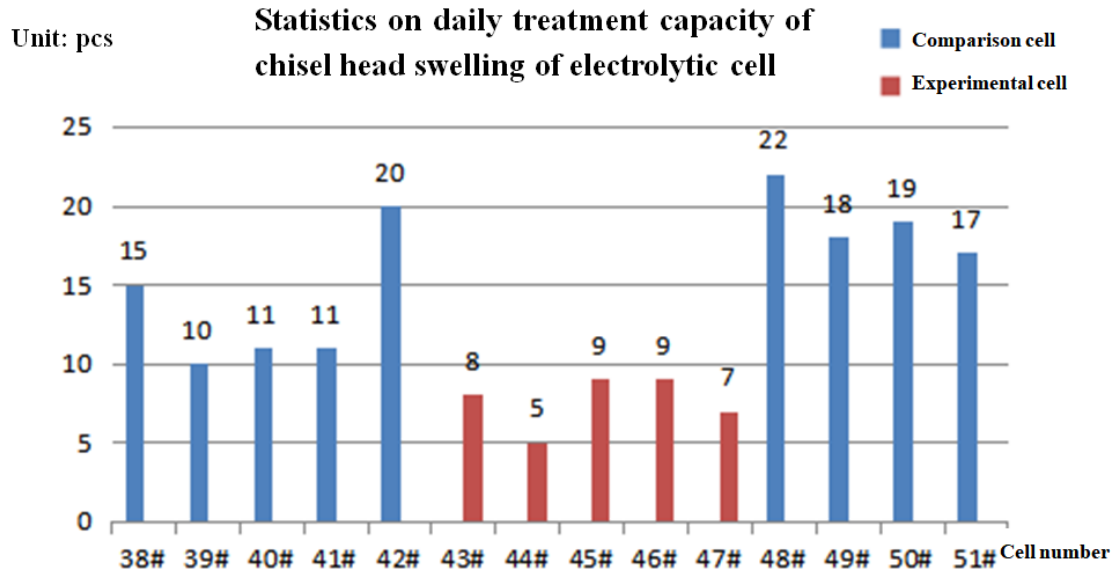

Figure 6. Histogram of daily treatment capacity of chisel head bath accumulation (swelling) of the electrolytic cells.

Figure 6 shows the daily need for treatment of chisel head bath accumulation per cell. It shows that the number of chisel head bath accumulations of the experimental cells that require manual intervention is reduced remarkably. 8 chisel head bath accumulations of experimental cells are treated manually per day, and 17 chisel head bath accumulations of comparison cell are treated manually per day. Therefore, the equipment can reduce the workload by 52 %.

4.3 Continuous Decrease of Anode Effect Frequency

Figure 7 shows the anode effect frequency of experimental cells over 14 weeks.

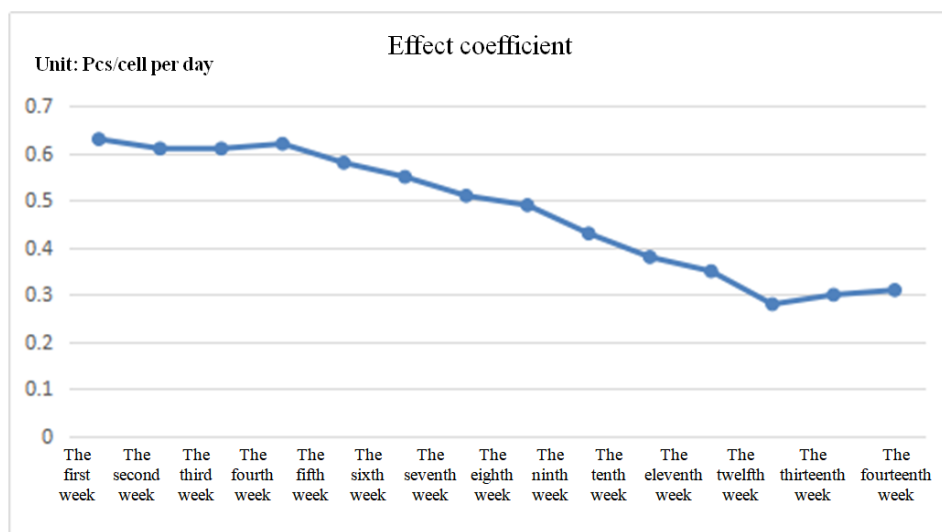

Figure 7. Statistical diagram of the anode effect frequency of experimental cells.

The anode effect frequency of experimental cells before installing the equipment was 0.6 /cell-day on average, but it was 0.3 /cell-day after the experiment, which is reduced by 0.3 /cell-day. After installing the equipment, the anode effect times of electrolytic cell can be reduced obviously.

5. Conclusion

The blocking detection accuracy of system is up to 94 %, the daily treatment need of chisel head bath accumulation is reduced by 52 %, the anode effect frequency is reduced by 0.3 /cell-day, and the equipment can operate stably. Therefore, the system can effectively solve the problems of blocking and chisel head bath accumulation.

Moreover, the system fills the gaps of accurate and real-time detection of feed hole state and intelligent crust-breaking technology. By tracking the motion trajectory of cylinder and using the neural network algorithm, the system can accurately monitor the state of feed hole in real time. The traditional stationary crust-breaking mode is transformed into on-demand crust-breaking mode, which realizes intelligent control, effectively ensures the openness of feed hole, inhibits the chisel head bath accumulation, reduces the anode effect frequency and labor intensity and guarantees stable operation of electrolytic cell. So far, the system has been applied to many electrolysis aluminum smelters and has been remarkably successful.

6. References

1. Qiu Zhuxian, *Aluminum Metallurgy with Pre-Baked Cells* [M], Metallurgical Industry Press, Beijing, January 2005.
2. Feng Naixiang, *Electrolytic Aluminum* [M], Chemical Industry Press, May 2006. *Operation Manual of Intelligent Crust-breaking and Feeding System*, Zhengzhou Nonferrous Metals Research Institute Co., Ltd. of CHALCO.