

## A comparison between various pump systems for high flow rate tailing pipelines

H. Krimpenfort <sup>1</sup>, T. Rassmann <sup>2</sup>, A. Pavlov <sup>3</sup>, Ralf Scherer <sup>4</sup>

1. Key Account Manager

FELUWA Pumpen GmbH, Germany

2. Thoralf Rassmann

Regional Director Russia

FELUWA Pumpen GmbH Representative Office, Moscow, Russia

3. Alexander Pavlov

Area Sales Manager

FELUWA Pumpen GmbH, Germany

4. Sales and Marketing Director

FELUWA Pumpen GmbH Representative Office, Moscow, Russia

Corresponding author: a.pavlov@feluwa.ru

### Abstract

Large mines produce tailings in high volumes. As suitable large tailings storage facilities are becoming scarce and difficult to find, tailings need to be transferred over longer distances than before. These longer distances, especially when a high positive static head and an extended transfer length have to be covered, require high discharge pressures. For this purpose, a number of alternative pumping systems are available. The first and most traditional method is to use centrifugal pump systems with multiple pumps in series. Over the last several years however, piston diaphragm pumps have also been successfully used for many such applications, especially at high and very high discharge pressures. Centrifugal pumps installed in series are usually applied at high flow rates at system pressures up to a maximum of 45-55 bar. Piston diaphragm pumps find application at lower flow rates and at pressures above 35 bar. In this paper, a train of centrifugal pumps will be compared with conventional (medium flow rate) piston diaphragm pumps and with high flow rate piston diaphragm pumps, which have recently become available and operate successfully. The comparison is based on an undefined type of tailings at a flow rate of 5,000 m<sup>3</sup>/hr. The selected discharge pressure is 50 bar, for which traditionally centrifugal pumps are used. This paper will show that at these lower discharge pressures and higher flow rates, piston diaphragm pumps offer a very feasible alternative. All key figures of CAPEX and OPEX parameters are compared, resulting in a payback period calculation, accompanied by a sensitivity calculation with different OPEX parameters. In addition to the commercial differences between the various systems, technical aspects will also be discussed. This paper will show that high-capacity piston diaphragm pumps are the most feasible solution for high flow tailings applications.

**Keywords:** tailings slurry, pipeline transfer, pump systems, hydrotransport, comparison.

### 1. Introduction

Mineral resources are becoming more difficult to find and less-accessible locations need to be explored and exploited to mine these minerals. In addition, environmental and safety conditions are becoming stricter, especially regarding tailings storage facilities (TSFs). Suitable TSFs are therefore also more difficult to find and need to be constructed at more remote locations and at higher costs. This also applies especially to existing mines at which the existing TSF capacity has reached its limit. In such cases, a new TSF needs to be built at a location further from the processing plant, which requires higher pressures. Also, in many cases, tailing flows of different

mine sites need to be combined and transferred to a common TSF. The combination of remote locations and combined tailings flow results in elevated discharge pressures and high flow rates.

## **2. Methodology and Options**

For the transfer of high flow rates at elevated discharge pressures, a number of pumping alternatives are available.

### **2.1. Centrifugal Slurry Pumps**

The first and most commonly used method is the application of centrifugal pumps in series. In order to reach an elevated discharge pressure, typically, trains often consisting of up to five or eight such pumps in series need to be installed per station. In cases where more pumps are required, a booster station along the pipeline may be required. Although the initial investment costs of these systems are low, the operating costs are usually quite high. A large part of this higher cost is due to the relatively low efficiency of centrifugal slurry pumps when compared to diaphragm pumps (PD) pumps. When averaged over a complete wear cycle of the centrifugal pump, efficiency in most cases will fall in the range of 50-70%. Another factor which results in high OPEX is the consumption of high-wear parts and associated down time and costs. The abrasive slurry flows through the pump typically at an impeller tip speed of up to 25 m/s. As the slurry is in direct contact with the pump volute, wear plate and impeller, these components have to be replaced at regular intervals. Consequently, the availability of each individual pump is rather low. Since a pump train consists of multiple pump sets, the availability of a complete pump train, which is critical to ensure a reliable operation, is very low. Another fact which contributes to the low availability of multiple pump trains, is that the shaft of centrifugal pumps needs to be flushed by a gland seal water system. The pressure of this system needs to increase at every stage in the train by 4 or 5 bar, which is difficult to control and makes the system vulnerable and potentially less unreliable. The low availability of each pump set in combination with the vulnerability of the gland water system results in a very low system availability. In order to guarantee a satisfactory availability, the majority of tailings pipelines are therefore equipped with at least one train of similar configuration. Some operators even prefer to have a third train of pumps to their disposal: one operating, one standby and one under repair. The capacity of a centrifugal pump is dependent on its discharge pressure (further explained in Chapter 6 of this paper). Whenever pressure increases/capacity decreases, the possibility of settling of solids and the risk of a plug is considerable. For this reason, a positive displacement pump is often installed for deblocking purposes, which increases the total CAPEX of the entire system.

### **2.2. Medium-Capacity Piston Diaphragm Pumps**

An alternative for such centrifugal pumps in series is the use of piston diaphragm pumps of which the discharge pressure is, in principle, nearly unlimited, but in practice usually does not exceed 250 bar.

Therefore, booster stations along the pipeline are rarely required. Traditionally, the capacity of such pumps is rather limited (typically 650-700 m<sup>3</sup>/hr). In order to reach a high capacity, a number of such pumps need to be installed in parallel. Obviously, the CAPEX of piston diaphragm pumps, when compared to centrifugal pumps, is relatively high. This is especially the case with conventional low to medium-capacity PD pumps of which many units need to be used in parallel. These high CAPEX costs are however, depending on certain conditions, offset by low OPEX costs. The mechanical efficiency of piston diaphragm pumps lies in the range of 85-90%. The difference with centrifugal pump systems is therefore at least 20%. This difference, especially when tailings pipelines are being used continuously and at high energy prices, leads to significantly lower annual energy costs for the piston diaphragm pump. Furthermore, the consumption of parts that wear in piston diaphragm pumps is much lower than for centrifugal

pumps. As the abrasive slurry is separated from the main pump components by means of a rubber diaphragm, the only moving parts of the pump which are in contact with the slurry are the suction and discharge valves. Consequently, these are the only components subject to wear. The slurry flows through these valves at a velocity of less than 2 m/s, which is significantly lower than that of the centrifugal pumps mentioned earlier. The combination of low energy costs and low cost of wearing parts leads to very low operating costs. As the down time of piston diaphragm pumps required for replacement of wearing parts is very low, their availability is high (usually in excess of 98%). Standby pumps are therefore not always required. However, such pumps are usually installed as an extra precaution. Contrary to centrifugal pumps, the capacity of PD pumps is in principle independent of its discharge pressure. In case of an increasing discharge pressure, the capacity of the pump will remain constant, as long as the same stroke rate is maintained. In case of a blocked pipeline, a PD pump has the capability to remove plugs, without the need of an additional PD pump for this purpose. This benefits the CAPEX of the entire system.

### 2.3. High-Capacity Piston Diaphragm Pumps

Several years ago, piston diaphragm pumps were introduced with a capacity of 1,000 m<sup>3</sup>/hr. The operating principle and the advantages of these high-capacity pumps are the same as for the medium-capacity piston diaphragm (MCPD) pumps described previously. The OPEX, therefore, are very similar. The difference lies in the fact that fewer pump units are required to reach the same flow rate. As the price of these large pumps is lower (per m<sup>3</sup> of pumping capacity) than of traditional piston diaphragm pumps, the initial investment of all pumps combined will also be lower. The difference in pump CAPEX is further enhanced by the fact that less auxiliary equipment (piping, cabling, valves and other infrastructure, also known as balance of plant, or BOP) will be needed, less foundations are required and the entire pump station will have a smaller footprint. The total CAPEX of the pump station will, therefore, be lower. For clarity, it should be noted that piston diaphragm pumps, regardless of their size, need a positive pressure on the suction side of the pump. This pressure is usually in between 1 and 3 bar and can either be provided by a satisfactory static slurry level in the suction tank or (in most cases) by centrifugal-type charge pumps. These charge pumps are of the same type as described previously, with the same features (low efficiency, high wear part consumption, etc.). As the discharge pressure of these charge pumps is maximum 5 bar, only one pump is required. The influence on the CAPEX and OPEX of the piston diaphragm pump station is limited.

## 3. Basic Data

For this comparison, a tailings pipeline with a capacity of 5,000 m<sup>3</sup>/hr was selected. Although this may seem like a high flow rate, it should be realised that many tailings pipelines operate at this, or in quite a few cases, even higher capacities. This applies especially to the oil sand fields in Alberta, Canada, where the tailings pipeline capacity often exceeds 10,000 m<sup>3</sup>/hr. Other mining applications are Tala bre in Chile and another (yet unnamed) pipeline in Peru, which are both expected to have a slurry capacity of 16,000 m<sup>3</sup>/hr. Multistage centrifugal pumps are primarily used on system pressure requirements of up to approximately 50 bar. It is generally accepted that at above 55 bar, the number of pumps required makes operation overly complicated and costly. At pressures of 55 bar or more, piston diaphragm pumps are historically applied. It should be noted, however, that depending on certain conditions, PD pumps also find application at pressures well below 50 bar. For this comparison, a discharge pressure of 50 bar was chosen for which both, centrifugal pumps as well as piston diaphragm pumps can be used. Other operating parameters, such as solids concentration, viscosity, pipeline profile and such, have not been considered in this comparison. Only the basic pump data of 5,000 m<sup>3</sup>/hr at 50 bar are taken into consideration. The subject pump station is located in a rather remote location at a high altitude with snow fall, which requires the need for a covered pump building to protect the pump and their operators from the weather conditions. Other data which are of importance are the abrasivity of the tailings, the price

of power, the cost of labour and water. The abrasivity has an effect on the cost of part-wear for both types of pumps. As a basis for this analysis, a medium abrasive type of tailings was selected with a Miller number of 100. The price of power obviously has an important effect on the operating costs and is EUR 0.12 per kWhr. For both the abrasivity and the power price, different numbers will be compared, which are summarised in a sensitivity analyses. The price of labour does not have a significant effect on the OPEX as part-wear and power costs do. However, to be complete it has been included in the equitation at an hourly rate of EUR 30.00. The cost for gland water is EUR 0.40/m<sup>3</sup>. The number of operating hours per year is 8,500. These basic data are summarised in Table 1.

**Table 1. Basic data.**

Pressure (bar)	50
Capacity (m <sup>3</sup> /hr)	5,000
Price per kWhr (EUR)	0.12
Operating hours (year)	8,500
Labour cost per hour (EUR)	30
Gland seal water costs per m <sup>3</sup> (EUR)	40

#### **4. Pump Alternatives**

For a flow rate of 5,000 m<sup>3</sup>/hr at a pressure of 50 bar, the previously mentioned pump types are considered. They are compared for this particular flow rate and pressure requirement.

##### **4.1. Centrifugal Pumps**

The maximum discharge pressure of slurry-type centrifugal pumps is usually limited to approximately 4-6 bar. In order to reach a pressure of 50 bar, 10 pumps in series are required. A train of 10 pumps in series in a single pump station is technically certainly possible. Practically, however, among others for reasons of availability, such trains are divided over two pump stations: one at the thickener and a second station at an appropriate intermediate point in the pipeline. This configuration is applied in this study. As the availability of individual slurry centrifugal pumps is approximately 96%, the availability of a pump train with five pumps is limited to 77%. In order to ensure maximum availability, a standby train will be required. Consequently, the centrifugal pump system will consist of two pump stations, each equipped with an operating train with five pumps and an identical standby train. The pumps selected for this application are 18/20 size slurry pumps with a capacity of 5,000 m<sup>3</sup>/hr. They are driven by 1,000 kW medium voltage motors. In order to adjust the flow rate of each pump train, one out of five pumps per train are equipped with medium voltage variable speed drives. The average price for these pump sets (pump, gearbox and motor) is quoted to be approximately EUR 400,000. Including variable frequency drive (VFD), the price is EUR 650,000. The pumps require a large quantity of auxiliary equipment to keep them running satisfactorily. This auxiliary equipment, also called BOP, consists of piping, cabling, switchgear, transformers, strainers, isolation valves, etc. Depending on the type of study, pipeline engineering companies use a 'rule of thumb' factor to calculate the cost of the BOP, which is based on their experience in the design of these stations. This factor varies from one engineering company to another. Usually, a multiplier of two is applied to the accumulated price of the centrifugal pumps to estimate the price of the BOP. The BOP also includes the extra costs for the construction of two separate pump stations (rather than one) and of extra cabling, gland water piping, etc. The efficiency of these huge centrifugal pumps is estimated to average 68% over the wear life of the pump. As the slurry is considered to be abrasive, the annual consumption of

wearing parts is estimated to be 50% of the CAPEX of the pumps. It should be noted that this percentage is applied to the price of the pump only. It excludes part-wear consumption of the gearbox, motor and VFD. The CAPEX of the piston-type deblocking pump is EUR 600,000 including drive. A factor which should not be ignored in these multistage systems is the supply of gland water to the stuffing box of each slurry pump. This requires a complicated and vulnerable system, based on a small piston pump which supplies clean water to the shaft of the centrifugal pump. At each stage in the pump train, the pressure of the gland water needs to be higher than the discharge pressure of the prior slurry pump. The vulnerability of this system decreases the availability of the entire pump train. This comparison is based on seal water consumption of 1.5 m<sup>3</sup>/hr per pump at an average total system pressure of 23 bar (slightly above the discharge pressure in the last stage of 46 bar). In addition, the cost of gland water needs to be considered. The cost of clean water (assumed to be EUR 40 per m<sup>3</sup>), based on a consumption of 1.5 m<sup>3</sup>/hr per pump by 10 operating pumps at 8,500 hours per year, however, is relatively minor.

#### **4.2. Medium Capacity Piston Diaphragm Pumps**

The maximum capacity of a traditional (three-cylinder single acting) piston diaphragm pump is approximately 650-700 m<sup>3</sup>/hr, regardless of the discharge pressure. For higher capacities, the pump components would need to be too large and heavy to guarantee safe operating and maintenance conditions, as well as a low net positive suction head required (NPSHr). For a total flow of 5,000 m<sup>3</sup>/hr, a total of seven operating pumps would be required. Although the availability of these pumps is 98% or more, an extra standby pump needs to be installed to warrant 100% availability of the system. The pumping pressure of PD pumps is, in principle, unlimited. Therefore, only one pump station is required which is equipped with these MCPD pumps. As mentioned earlier, the PD pump needs to be fed by a centrifugal-type charge pump which is basically identical to the centrifugal pumps described in the previous paragraph. Also, these charge pumps require a gland water system which, however, consists of only one stage. The gland water system is therefore much simpler and does not consume as much water and power. Each pair of two PD pumps can be fed by a single centrifugal-type charge pump. Thus, a total of four centrifugal pumps is required. In addition, an extra centrifugal pump needs to be available for standby purposes. The average price of such medium-capacity PD pumps is approximately EUR 2,300,000, which includes an external gearbox and a 1,400 kW medium voltage motor with variable speed drive. The price for the charge pumps (1,500 m<sup>3</sup>/hr at 3 bar pressure) is estimated to be EUR 80,000, including gearbox and constant speed motor. The overall efficiency of piston diaphragm pumps is typically in excess of 85%. As the only parts that wear from contact with the slurry are the suction and discharge valves, the annual part-wear cost (based on operational experience) is 4-5% of the CAPEX of the pumps. To cover the part-wear costs of the charge pump, an extra 1% is added. As with centrifugal pumps, this percentage is applied only to the pump, not to the gearbox, motor and VFD. The quantity of BOP (piping, valves, cablings, switchgear, etc.) required to keep these big pumps running is less than that for centrifugal pumps, especially with two stations with 5 + 5 of such pumps in series. The rule of thumb factor usually applied to calculate the cost of the BOP is in between 1 and 1.5. In this comparison, we have calculated with a factor of 1.2. It should, however, be considered that the CAPEX of PD pumps is much higher than that of centrifugal pumps, even when there are 2 x 5 of such pumps in series in two-pump stations. Floor space required (including maintenance area) for eight pumps is estimated to be approximately 2,000 m<sup>2</sup>.

#### **4.3. High-Capacity Piston Diaphragm Pumps**

The pumps that are selected in this comparison as high-capacity piston diaphragm pumps are FELUWA-type QGK500 double hose diaphragm pumps. These are of five-cylinder single-acting configuration and have been in operation very successfully at the Boleo Copper mine, Baja California, Mexico since 2013. The pumps have a maximum capacity of 1,000 m<sup>3</sup>/hr.

Consequently only five of such pumps are required to transfer the total quantity of 5,000 m<sup>3</sup>/hr through the pipeline. As with the MCPD pumps, an extra standby pump is required to guarantee maximum availability. The six pumps are fed by three charge pumps, plus two standby. The price for the five-cylinder pump is approximately EUR 2,800,000, including MV motor and VFD. The other parameters (efficiency and part-wear consumption) are the same as that of the traditional MCPD pumps. As the charge pumps for the high-capacity PD pumps are somewhat higher than for the medium-capacity pumps, the price is also higher. The footprint for six of these pumps (including maintenance area) is approximately 1,400 m<sup>2</sup> which is 30% less than what is required for the smaller MCPD pumps. This difference can be explained by the fact that traditional piston diaphragm pumps are equipped with flat circular diaphragms which make the pump relatively wide. The five-cylinder pump has tubular diaphragms which make this design much more compact. Due to the reduced number of pumps and their smaller footprint, the pump station will be smaller. Consequently, a multiplier for BOP of one is included in the calculations.

## 5. Calculations and Results

A number of parameters which determine CAPEX and OPEX of each type of pump station is compared. In the following tables, these costs are summarised and the difference in costs between the systems are indicated.

### 5.1. CAPEX

The investments for pumps and BOP including pump housing, specified in Section 4, for each system are shown in Table 2. To cover the costs for engineering, procurement and construction management (EPCM), 12% has been added, and an additional 15% has been added for contingencies. It is obvious that the CAPEX for centrifugal pumps is considerably lower than that for PD pumps. However, when BOP is included, this difference is significantly reduced, especially in the case of high-capacity PD pumps.

**Table 2. CAPEX comparison.**

	<b>Centrifugal Pump 2x (5 + 5) 5,000 m<sup>3</sup>/hr</b>	<b>MCPD 7 + 1 713 m<sup>3</sup>/hr</b>	<b>HCPD 5 + 1 1,000 m<sup>3</sup>/hr</b>
Number of required pump units	20	8	6
Price per pump (average including gearbox, motor, VFD) (EUR)	450,000	2,300,000	2,800,000
No. of operating pumps	10	7	5
No. of standby pumps	10	1	1
No. of charge pumps for PD pumps	—	4	3
No. of standby charge pumps	—	2	2
Price per charge pump (EUR)	—	80,000	120,000
Deblocking piston pump (EUR)	600,000	Not applicable	Not applicable
Calculation			
Total system pump CAPEX (EUR)	9,600,000	18,880,000	17,400,000
CAPEX of BOP and pump station (EUR)	19,200,000	22,656,000	17,400,000
Total direct cost (EUR)	28,800,000	41,536,000	34,800,000
EPCM (12%) (EUR)	3,456,000	4,984,320	4,176,000
Contingency (15%) (EUR)	4,320,000	6,230,400	5,220,000

	<b>Centrifugal Pump 2x (5 + 5) 5,000 m<sup>3</sup>/hr</b>	<b>MCPD 7 + 1 713 m<sup>3</sup>/hr</b>	<b>HCPD 5 + 1 1,000 m<sup>3</sup>/hr</b>
Total CAPEX pump station(s) (EUR)	36,576,000	52,750,720	44,196,000
Difference in investment (EUR)	—	-16,175,720	-7,620,000

## 5.2. OPEX

The operating expenditure of these pump systems are mainly determined by power, part-wear, and, to a lesser extent, labour and gland seal water consumption. The cost for financing has not been considered.

### 5.2.1. Power Consumption

Power consumption and cost are the biggest contributing factors to the total of operating costs. Depending on the efficiency of the pumps and the electricity price, power costs for centrifugal pumps can contribute 75% to the OPEX. For PD pumps, the cost of power can be as high as 90%. This is mainly caused by the fact that the other OPEX costs (especially part-wear) for these pumps are relatively low. In Section 5.3, the influence of a higher or lower kWhr price is shown. Costs for power consumption are compared in Table 3.

**Table 3. Comparison of power costs.**

	<b>Centrifugal pump 2 x(5+5) 5,000 m<sup>3</sup>/hr</b>	<b>MCPD 7 + 1 713 m<sup>3</sup>/hr</b>	<b>HCPD 5 + 1 1,000 m<sup>3</sup>/hr</b>
Pressure (bar)	50	50	50
Capacity (m <sup>3</sup> /hr)	5,000	5,000	5,000
Price per kWhr (EUR)	0.12	0.12	0.12
Operating hours (year)	8,500	8,500	8,500
Assumed efficiency (%)	68	88	88
Calculation			
Absorbed power (kW)	10,212	7,891	7,891
Hourly power cost (EUR)	1.22	946	946
Annual power cost (EUR)	10,416.666	8,049,242	8,049,242
Difference in power consumption per year (EUR)	—	2,367,424	2,367,424

### 5.2.2 Part-Wear Consumption

After the cost of power, costs for the wear of parts are the most important share of the OPEX of slurry pumps. This applies especially to centrifugal pumps where the, in this case medium abrasive, slurry is in direct contact with large and expensive pump components. Consequently, part-wear costs are about one third of the total operating expenditure of these pumps. For piston diaphragm pumps, only the suction and discharge valves are in contact with the slurry and part-wear costs are therefore approximately 5%.

As mentioned before, the PD pumps are fed by centrifugal type charge pumps, with 50% part-wear costs of the CAPEX of these pumps. A total part-wear cost factor of 5% has been used (Table 4).

**Table 4. Comparison wear parts costs.**

	<b>Centrifugal Pump 2x (5+5) 5,000 m<sup>3</sup>/hr</b>	<b>MCPD 7+1 713 m<sup>3</sup>/hr</b>	<b>HCPD 5+1 1,000 m<sup>3</sup>/hr</b>
Parts consumption in % of purchase price (%)	50	5	5
Calculation			
Annual pump wear cost (EUR)	1,406,250	483,000	420,000
Difference in wear parts costs per year (EUR)	-	923,250	986,250

Also varying costs of wear parts for centrifugal pumps are reviewed in Section 5.3.

### 5.2.3. Labor Costs

Labor costs play a relatively minor role in the operating costs for slurry pumps. For completeness sake, however, these have been included in this comparison. The main components of centrifugal pumps need to be replaced frequently. This is expensive and time-consuming. The number of hours which need to be spent on maintenance and replacement of these pumps is therefore much higher than for PD pumps. As the quantity of centrifugal pumps is much higher, the labour costs for all of these pumps are considerably higher. The difference in maintenance hours between the traditional and high-capacity PD pumps can be explained by the fact that the traditional pump has three cylinders with six valves, whereas the five-cylinder pump has 10 sets of valves. As only six of these high-capacity pumps are required, rather than eight, the total labour costs are still slightly less. Details can be found in Table 5.

**Table 5. Comparison labour costs.**

	<b>Centrifugal pump 2x(5+5) 5,000 m<sup>3</sup>/hr</b>	<b>MCPD 7 + 1 713 m<sup>3</sup>/hr</b>	<b>HCPD 5 + 1 1,000 m<sup>3</sup>/hr</b>
Number of required pumps	20	8	6
Maintenance man hours per year per pump (hrs)	300	200	250
Labour cost per hour (EUR)	30	30	30
Calculation			
Annual labour maintenance costs (hrs)	180,000	48,000	45,000
Difference in labour costs per year (EUR)	—	132,000	135,000

Varying labour costs have not been included in the sensitivity analyses, as the impact of these costs on the total OPEX is limited.

### 5.2.4 Gland Seal Water Costs

The cost for gland seal water (Table 6) is, compared to power and part wear, very limited. The influence of the gland water system on the vulnerability of the centrifugal pump is much more important than its influence on the OPEX. Gland seal water consumption is based on 1.5 m<sup>3</sup>/hr per

pump at a price of EUR 0.40 per m<sup>3</sup>. Dilution of the tailings by the gland water has not been considered as this is only minor — in the case of centrifugal pumps, only 15 m<sup>3</sup>/hr on a total flow of 5,000 m<sup>3</sup>/hr.

**Table 6. Comparison gland seal water costs.**

	<b>Centrifugal pump 2 x (5 + 5) 5,000 m<sup>3</sup>/hr</b>	<b>MCPD 7 + 1 713 m<sup>3</sup>/hr</b>	<b>HCPD 5 + 1 1,000 m<sup>3</sup>/hr</b>
Power cost gland water pumps (EUR)	11,475	4,590	3,442
Gland seal water consumption (at 1.5 m <sup>3</sup> /hr per pump) (m <sup>3</sup> /y)	127,500	51,000	38,250
Gland seal water cost (at EUR 0.40/m <sup>3</sup> ) (EUR)	51,000	20,400	15,300
Calculation			
Annual costs gland seal water system (EUR)	62,475	24,990	18,742
Difference gland seal water costs per year (EUR)	—	37,485	43,732

### 5.2.5. Summary

The result of the comparison of the aforementioned parameter is summarised in Table 7. Based on the specified assumptions, the amortisation period for extra costs of the traditional PD pumps is 4.1 years. For the high-capacity pumps, this is reduced to 1.9 years, which is mainly driven by the fact that fewer pumps are required with lower costs for BOP.

**Table 7. Comparison summary.**

	<b>Centrifugal pump 2x (5 + 5) 5.000 m<sup>3</sup>/hr</b>	<b>MCPD 7 + 1 713 m<sup>3</sup>/hr</b>	<b>HCPD 5 + 1 1.000 m<sup>3</sup>/hr</b>
Annual power consumption (EUR)	10,416,666	8,049,242	8,049,242
Annual wear parts costs (EUR)	1,406,250	483,000	420,000
Annual labour costs (EUR)	180,000	48,000	45,000
Annual gland water costs (EUR)	62,475	24,990	18,742
Annual OPEX (sub-total) (EUR)	12,065,391	8,605,232	8,532,984
Contingency (15%) (EUR)	1,809,808	1,290,784	1,279,947
Total annual OPEX (EUR)	13,875,200	9,896,017	9,812,932
Difference in OPEX per month (EUR)		331,598	338,522
Total CAPEX (EUR)	36,576,000	52,750,720	44,196,000
Amortisation period of difference in investment (years)		4.1	1.9

### 5.3. Sensitivity Analyses

As shown in Figure 1, the main contributors to the OPEX of slurry pumps are the power and part-wear costs. Consequently, mainly these factors determine the amortisation period of the extra

costs for PD pumps when compared to centrifugal-type slurry pumps. For this reason, the costs of power and part-wear are subject to a sensitivity analyses where the price for electricity varies from EUR 8-15 cents per kWh and the part-wear costs for the centrifugal pumps varies from 30 (for light abrasive slurries) to 150% (for very abrasive slurries) of the CAPEX of the centrifugal pumps. The results of this analysis when compared to traditional PD pumps can be seen in Table 8, or graphically in Figure 1.

**Table 8. Result sensitivity analyses for MCPD.**

		% of CAPEX for centrifugal pumps spare consumption				
		30%	50%	70%	100%	150%
Electricity cost	8	6.7	5.3	4.4	3.5	2.6
(EUR cent/kWhr)	9	6.1	4.1	4.1	3.3	1.2
	10	5.6	4.6	3.9	3.1	2.4
	12	4.9	4.1	3.5	2.9	2.2
	15	4	3.5	3.0	2.6	2

Amortisation period varies from 6.7 years (low electricity price and low consumption of parts that wear) to two years (for high electricity price and high consumption of parts that wear) (Figure 1). Payback period in years, centrifugal versus MCPD.

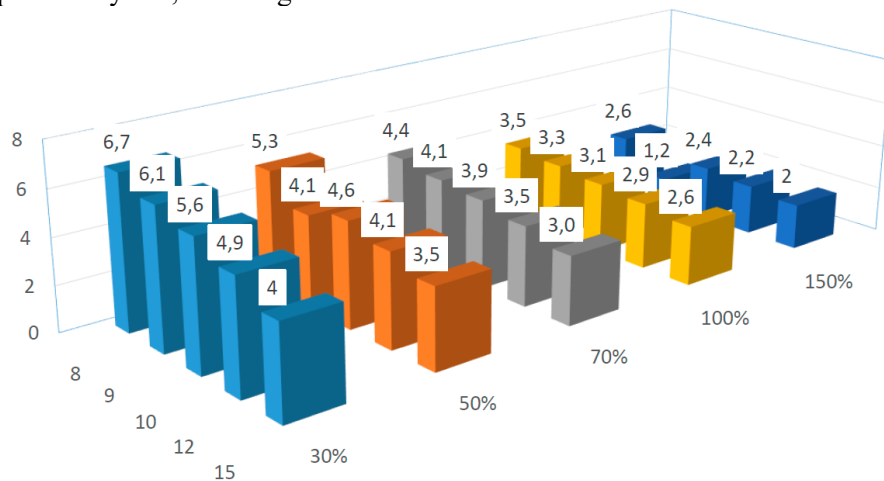

**Figure 1. Sensitivity analysis of MCPD.**

The same analysis regarding the amortisation period of traditional PD pumps has been made for high-capacity PD pumps. As can be expected, due to the lower CAPEX of these pumps, the payback period is much shorter than with the traditional MCPD pumps (Table 9 and Figure 2).

**Table 9. Result of sensitivity analysis for HCPD.**

		% of CAPEX for centrifugal pumps spare consumption				
		30%	50%	70%	100%	150%
Electricity cost	8	3	2.4	2	1.6	1.2
(EUR cent/kWhr)	9	2.8	2.3	1.9	1.5	1.2
	10	2.6	2.1	1.8	1.5	1.1
	12	2.2	1.9	1.6	1.3	1.0
	15	1.9	1.6	1.4	1.2	1

Payback period in years, centrifugal versus HCPD.

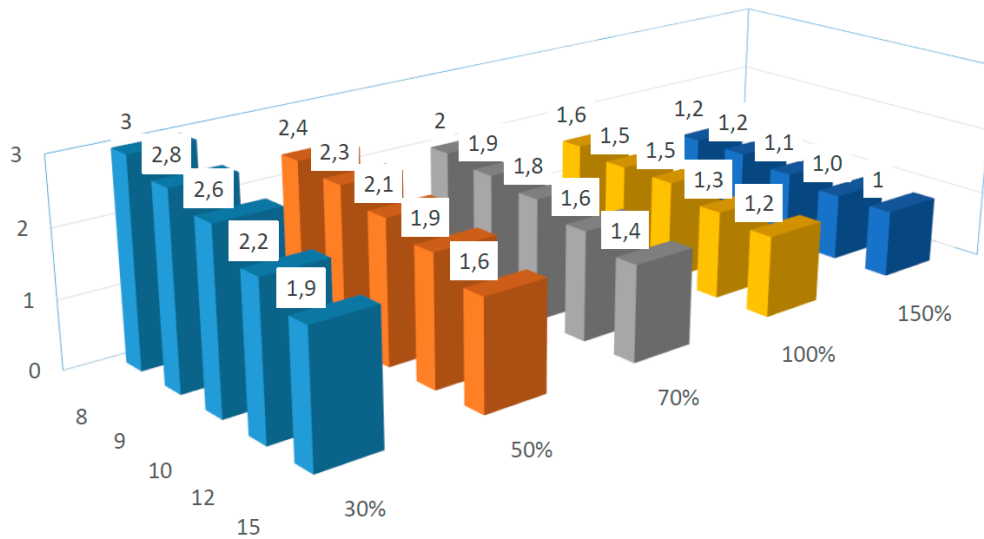

Figure 2. Sensitivity analysis.

## 6. Technical Features

In addition to operational expenditure advantages, PD pumps also offer technical features which are advantageous to this type of pump. The most important one is based on the principle that the pumping capacity of PD pumps is independent of the discharge pressure. The only way to vary the flow rate of PD pumps is to adjust the stroke rate. With centrifugal pumps, when the system pressure increases, the pump follows its pump curve which results in a reduced flow rate (Figure 3).

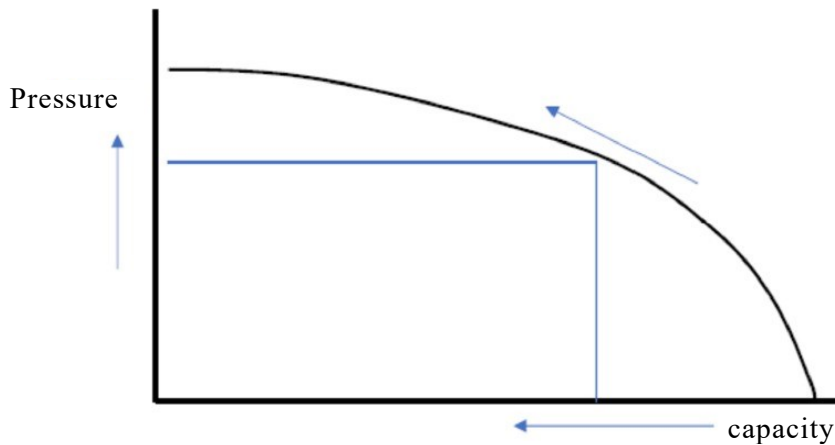

Figure 3. Pressure/capacity relationship for a centrifugal pump.

A reduced flow rate results in a decrease in the velocity at which the slurry flows through the pipeline.

Every slurry has a deposition point, below which solid particles in the slurry will start to settle on the bottom of the pipeline. If the slurry velocity drops below the deposition point, a layer of particles will start to build-up on the bottom of pipeline. The reduced diameter of the pipeline and increased velocity will result in an increase in required discharge pressure. This in turn will again

move the pump further back on the curve with a further reduction in flow rate as a result. This process can result in a vicious circle where the pump pressure ultimately will reach its closed valve position and does not produce any flow at all. This may be referred to as a pipeline blockage, but is more accurately stated as a system pressure exceeding the closed valve pressure capability of the pump. As no slurry will be discharged from the pump, consequently, the build-up of particles may block the pipeline. As the centrifugal pump is not able to produce any pressure to remove the plug in the pipeline, a separate, additional, positive displacement pump is required for deblocking purposes.

Especially in remote locations, or arctic conditions, a plug in the pipeline can be difficult to remove, which results in a long standstill of operations. The PD pump has different characteristics. Its capacity, therefore, does not depend on its discharge pressure (Figure 4). As long as sufficient power to drive the pump is available, the pressure-bearing components (discharge manifolds, valves, diaphragm housings, and pulsation dampener), as well as the rod load of the crankshaft, are suitable. The pressure can be increased without any reduction in flow rate or other consequences. For this reason, the risk of a blocked pipeline is substantially reduced. In the unlikely event of a plug in the line, the PD pumps, which are used to transfer the slurry, will be able to produce sufficient pressure for removal of the plug. An additional PD pump will not be required for this purpose.

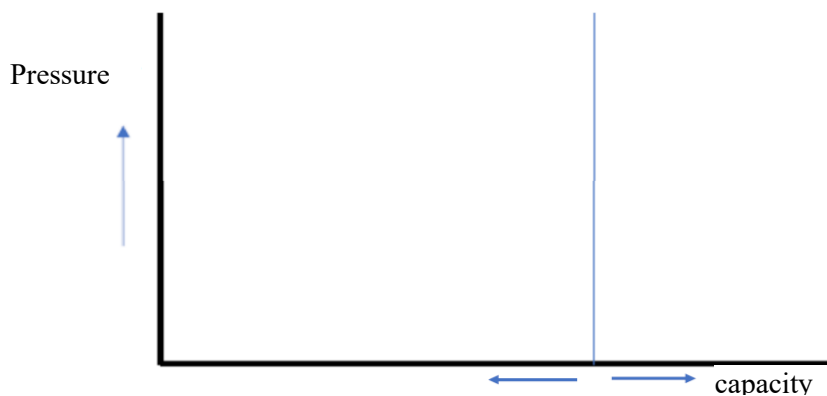

**Figure 4. Pressure/capacity relationship for PD pumps.**

Another feature of piston diaphragm pumps is that capacity does not vary with changes in slurry viscosity or specific gravity. This, with previously mentioned stable capacity features, allows for designing reliable slurry systems with much higher solid concentrations than would be considered practical with centrifugal pumps. This makes this class of equipment ideally suited for higher-density tailings systems and all of the benefits to cost and safety that these systems provide.

## 7 Conclusion

For this comparison, a pipeline application of 5,000 m<sup>3</sup>/hr at 50 bar has been selected. Although this may not represent the majority of existing hydrotransport slurry transfer applications, there are, however, already a number of pipelines in operation in similar conditions. Moreover, it can be expected that demand for such pipelines will increase for existing and future mines. In this paper, a number of operational cost factors have been considered, such as power and water, cost for part-wear and labour, pump pricing and commonly used costing criteria for CAPEX, in a comparison between centrifugal pump systems in series, traditional piston diaphragm pumps and high-capacity piston diaphragm pumps in parallel. Depending on the price of electricity and the abrasivity/consumption of parts that wear, the use of large piston diaphragm pumps for high flow rate slurry pipeline applications is proven to be feasible. Payback period for the extra CAPEX of

piston diaphragm pumps varies from 6.7-2 years for medium-capacity piston diaphragm pumps, depending on consumption of parts that wear, and the price of power. For high-capacity piston diaphragm pumps, this period is reduced to three years to one year, which makes this type of pump the most feasible option for high flow rate slurry pipelines. In addition to commercial advantages, piston diaphragm pumps offer the operational advantage that the risk of a blocked pipeline with these pumps is considerably less than with centrifugal pumps.