

Optimization of Combustion in Anode Baking Furnaces Due to Heavy Oil Injection Algorithm Development

Cláudio Cardins¹, Cléber Carneiro², João James³, Paulo André⁴ and Urubatan Dias⁵

1. Process Engineer
2. Automation Engineer
3. Process Technician
4. Process Technician
5. Area Manager

Albras Alumínio Brasileiro S.A., Barcarena, Brazil
Corresponding author: claudio.cardins.junior@albras.net

Abstract



The control of combustion for heavy oil is essential to ensure energy efficiency (an optimum fuel consumption) and anode quality during the baking process, as well as to avoid the accumulation of material resulting from poor combustion in the furnace exhaust pipes and emissions of pollutants to the environment. The present paper consisted in the development of an oil injection algorithm aimed at balancing the pulse ratio between the burners in the burners bridges. The fuel injection balancing avoids the excess oil addition in the fire zone using the optimization between the amount of oil injected in the burners in different positions of the Fire and the temperature into Flue Walls, maintaining as principal condition, the adherence to reference baking curve (set point). The results showed an excellent performance of the combustion of heavy oil in the furnaces, generating an improvement in the Anodes baking level, reduction in fuel consumption and drop in atmospheric emission levels.

Keywords: Heavy oil, optimization, baking furnace, environment.

1. Introduction

Anode quality deficiencies will increase the anode consumption in the cell. In most of the cases the cost of these low anode quality will exceed all cost of other optimization programs. Reducing the emissions also brings more savings, as improved off-gas quality will reduce the cost of exhaust and ring main cleaning. At the end, the most important factor for the metal production is the cost optimization. For instance, if a furnace is required to operate with an anode bigger than the furnace design it will likely decrease the refractory life and / or pitch burn combustion efficiency, even if it increases output in the short-term [1].

In October 2017, Albras Baking Furnace as started the implementation of a new algorithm to optimize the heavy oil injection. The objective was the reduction of the off-gas emissions during baking furnace operation and the increase of the baking level through the optimization of the amount of oil injected into the Furnace and thereby avoiding the heavy oil excess injection and improving the pitch burn in the pre-heating zone.

To adapt this algorithm, Albras Baking Service had to apply the fuzzy logic control system in order to improve the injection control. The changes were based on the observation and measurement of the operational performance, regarding the injection of oil in the furnaces in order to define the injection behavior in burner bridges.

This paper describes the improvement undertaken by a combination of Albras Baking Furnace's engineering team and Carbon Area Automation Engineering, both of whom worked together to develop an anode baking process that could better improved the Anode quality, this will result

to a better metal productivity. These improvements have been successfully implemented in the Albras Baking Furnace in Barcarena, Brazil.

2. Methodology

The original fuzzy logic control system was first proposed in 1965 by Lotfi Asker Zadeh. In modern times, it is a fundamental factor in whether a system is being considered technically "excellent" and is generally accepted in process control system.

Fuzzy logic is an extension of the Boolean logic. It was developed to express the concept of partial truth, so a value can be determined between the "completely true" and "completely false" limits. This means that a fuzzy logic value is any value in the range of 0 to 1.

Fuzzy logic is a critical concept to understand in control system engineering, as the world where we live is not divisible into categories of wholly true or wholly false information. Fuzzy logic can incorporate the human form of thinking into control systems. In this way, the fuzzy controller behaves according to the reasoning that the expert applies to infer with the rules based on the known information of the process.

The most important work can be seen in the change of the oil injection logic in the three burner bridges on the fires of the baking furnace. The engineers used the fuzzy logic to "replicate" automatically the function of the furnace operators in the burners as shown in Figure 1.

For this purpose, the ratio of pulses between the burners was balanced considering the temperature deviation of the baking curve temperature, but without causing an excess of oil injection during the process.

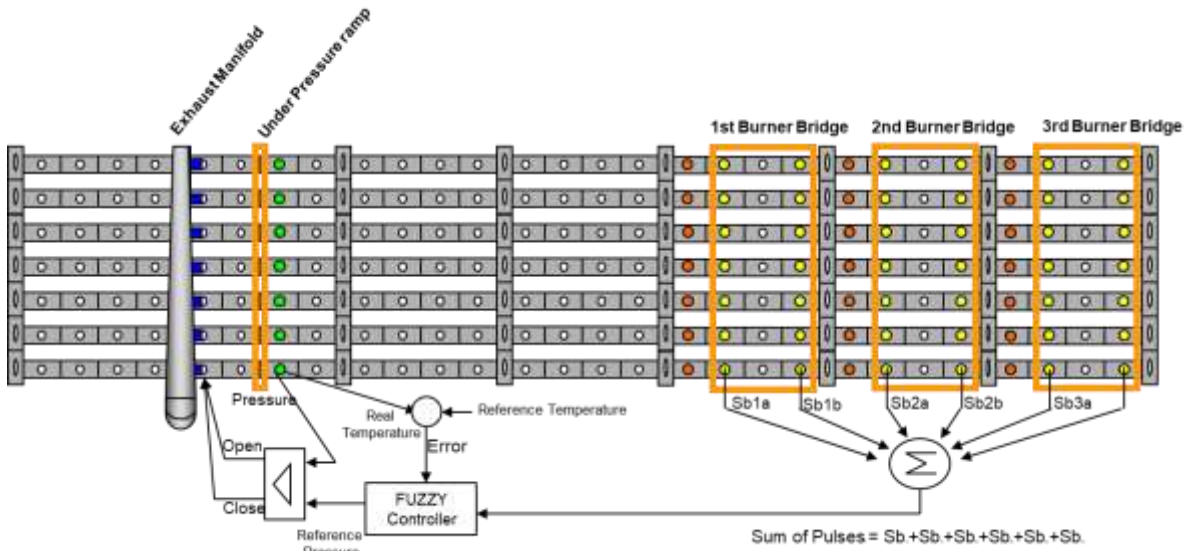

Figure 1. Albras baking furnace control system

4.3. Baking Temperature Level

As shown on Figure 5. This allowed an increase in the baking level, measured by Equivalent Temperature (Lc) [4] and a reduction of standard deviation.

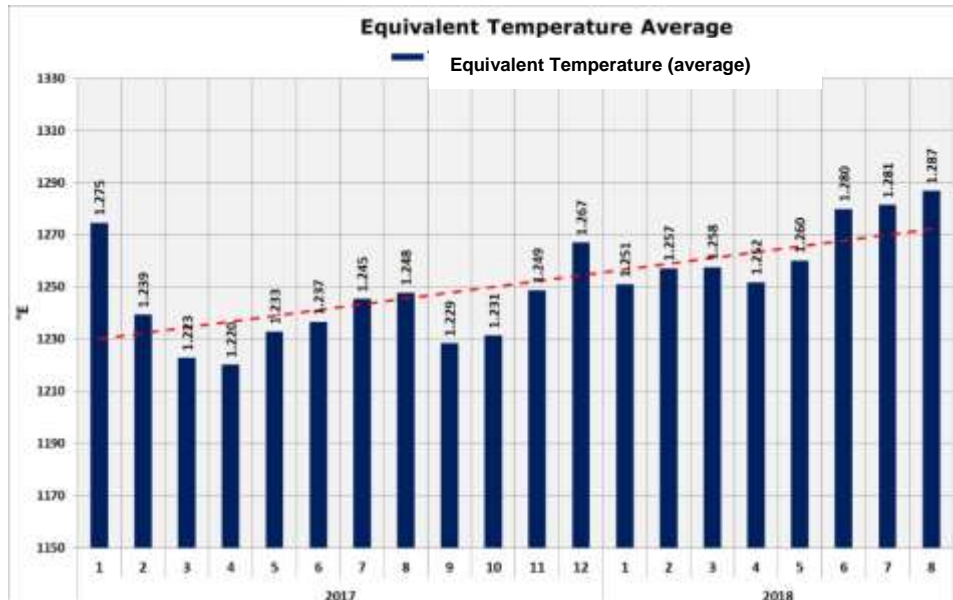

Figure 5. Baking level performance (measured by Equivalent Temperature).

5. Conclusion

The improvement in the algorithm used for the fuel injection in the baking furnace, has resulted in an optimization of the anode and emission performance. The main performance indicators (baking level, Off-gas opacity, % manual operation of burners and baking curve temperature adherence) was improved. This improvement has allowed the Albras baking furnace to achieve historic results in baking performance and environment emissions.

6. References

1. Felix Keller and Peter O Sulger, *Anode Baking – Baking of Anodes for the Aluminum Industry 2nd edition*, 2008, 220-221.
2. Fischer W.K. et al., Baking Parameters and the Resulting Anode Quality, *Light Metals* 1993, 684 – 694 .
3. R&D Carbon, *Anodes for Aluminium Industry 1995 – 2005*, 2nd edition.
4. International Organization for Standardization, *Carbonaceous material used in the production of Aluminium – Determination of baking level expressed by equivalent temperature*, ISO 17499:2006.