

Adaptive Fuzzy Controller to Regulate Anode Covering Material Recipe

Edson Cruz¹, Cléber Carneiro², João Benjamim³, André Ferraioli⁴ and Marionildo Costa⁵

1. Maintenance Engineer

2. Automation Engineer

3. Maintenance Engineer

4. Process Engineer

5. Process Technician

Albras Alumínio Brasileiro S.A., Barcarena, Brazil

Corresponding author: edson.cruz@albras.net

Abstract

An adaptive controller for keeping the Anode Covering Material (ACM) recipe feeding stably and efficiently is proposed in this paper. The controller is based on fuzzy logic control strategy by developing a method of adjusting the quantification and proportion factors. The selection of these factors makes a big influence on the static and dynamic performances of the controller. This new control strategy is implemented in Albras ACM Plants. The controller program was developed with ladder language and runs on Programmable Logical Controllers (PLCs) from Allen Bradley. ACM plants are operating with flowmeters which are being controlled by fuzzy controllers, and the feed rate, which is the control variable, works around the established operation point. The results demonstrate the effectiveness and viability of the system that hereafter will be implanted for other processes at Albras.

Keywords: Fuzzy control, self-optimization, flowmeter, anode covering material.

1. Introduction

One of the most important routine in the potroom operation is anode covering. Over the last decade dramatic developments have taken place in the preparation and optimization of anode cover material (ACM). Basically, the ACM is removed from the top of spent anodes or butts in the rodding shop, reclaimed and processed. It is normally composed of a hard, sintered portion from the lower part of the anode cover and a loose, dusty portion from its upper part. The main functions to be fulfilled by ACM consist in the protection of anode carbon against air oxidation and also thermal insulation against heat losses from the top surface of the anodes [1]. At Albras, the blending stations for preparation of the ACM recipe are located at the rodding shops. The blending is processed using separate silos for the ACM components (crust/alumina ratio) and individual proportioning flowmeters. Precise proportioning of ACM components is required to minimize the variability of physical properties and chemical composition. In accordance with the characteristics of the ACM blending process, a control strategy with a double-deck structure of self-optimizing and fuzzy control is developed and presented in this paper. This control strategy uses only input and output signals [2]. The organization of this paper is as follows. In the first section, is discussed in detail the proposed fuzzy logic controller. In the second section, an improvement is introduced to the fuzzy logic controller. Real time application results are given in the last section, which demonstrate that the proposed control strategy is practical and efficient.

2. Fuzzy Logic Control for Flowmeter

The structure of a fuzzy controller in the control loop are shown in Figure 1, where F (Fuzzification), KB (Knowledge Base), IM (Inference Machine) and D (Defuzzification). For

this SISO (single input, single output) system, a fuzzy controller with two dimensions is suitable, and its input variables are error E and the change of error E_c and the output variable U of the controller is the frequency increment to control the speed of the screw conveyor [3].

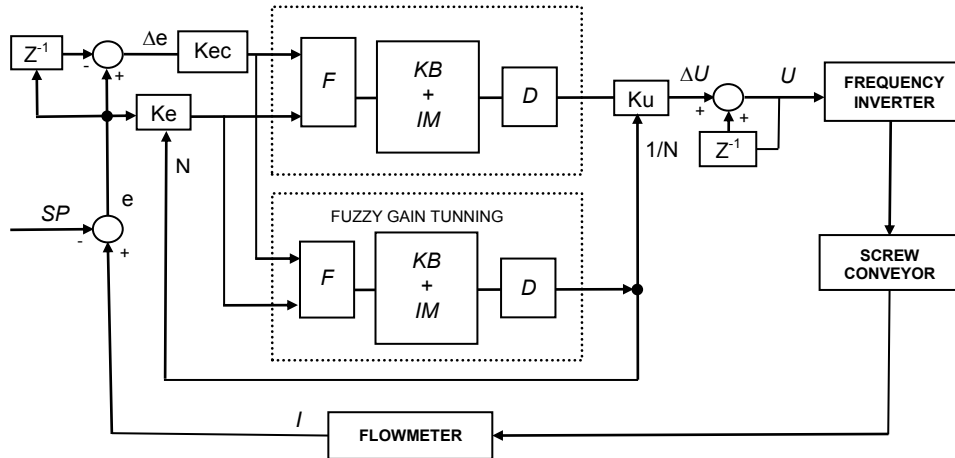

Figure 1. Structure of the fuzzy controller.

The Equations (1 – 3) describe the input and output variables respectively.

Input variables:

$$e(k) = I(k) - SP(k) \tag{1}$$

$$\Delta e(k) = e(k) - e(k - 1) \tag{2}$$

Output variable:

$$U(k) = U(k - 1) + \Delta U(k) \tag{3}$$

where:

- e Feed rate error
- Δe Change of the error
- I Feed rate
- SP Set Point
- U Frequency Increment

In the fuzzy controller presented above, the inputs are the error E , the change of error E_c and the output is the change of control U . The rules base is represented by 7 linguistic values, NB: Negative Big; NM: Negative Medium; NS: Negative Small; ZR: Zero PS: Positive Small; PM: Positive Medium; PB: Positive Big. Next, the membership functions and the domains of the fuzzy sets. The feed rate of the flowmeter is proportional to the screw conveyor speed signal (0 – 100 %, modulated by the frequency inverter). So, the basic domain of the error (possible normalized value) is: $E \in [-0.2, 0.2]$, while the basic domain of the change of error is $E_c \in [-0.04, 0.04]$. Let $K_e = 5$, $K_{ec} = 2.5$, where K_e is the quantification factor of error, K_{ec} is the quantification factor of the change of error. Thus, the domain of error is: $E \in [-1.0, 1.0]$; the domain of the change of error is $E_c \in [-0.1, 0.1]$. The basic domain of the output variable (0 – 10V) is: $U \in [0, 10]$; therefore, the basic domain of change of the control variable is: $U \in [-10, 10]$. Let $K_u = 10$, where K_u is the proportion factor. The fuzzy domain of the change of control is: $\Delta U \in [-1.0, 1.0]$. The membership function in the controller is triangular [4], as shown in Figures 2 - 4.

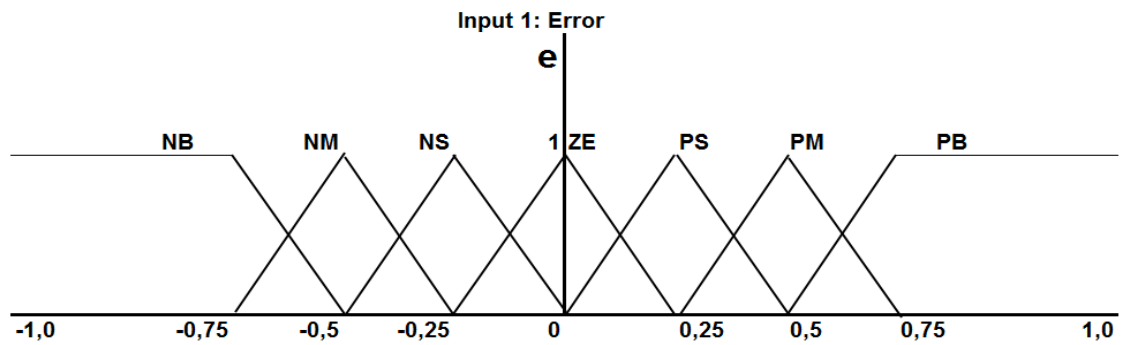

Figure 2. Membership of the Error.

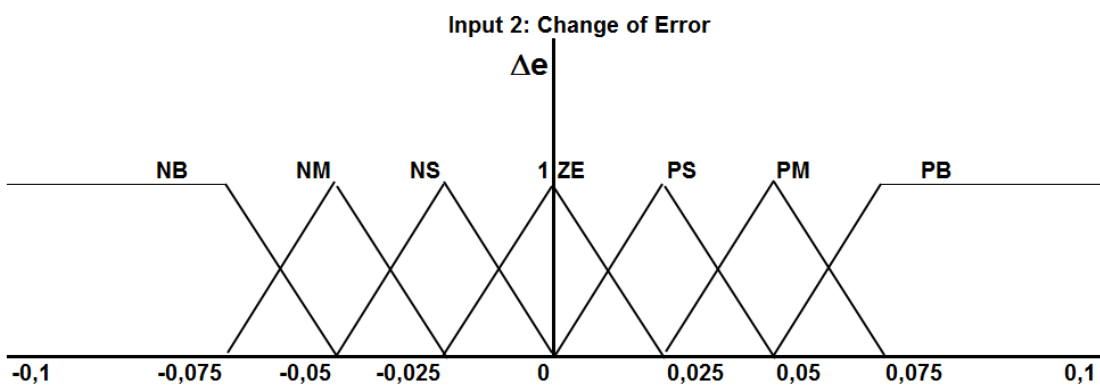

Figure 3. Membership of the Change of Error.

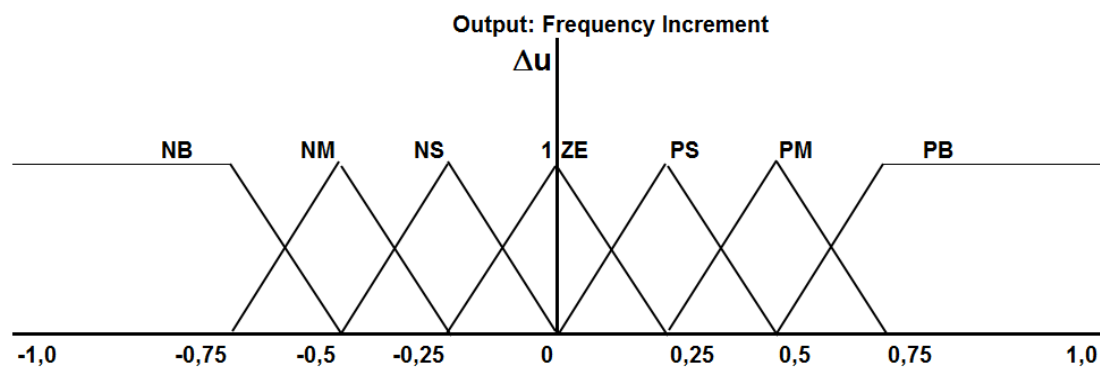

Figure 4. Membership of the Output.

For the controller where error and change of error is input, and change of control is output, the so-called Mamdani rule was used as the control rule [5 - 6] (see Table 1). The compositional rule is max-min; the center of gravity law is applied in the defuzzification of the output variable. In accordance with the characteristics of a flowmeter, a control strategy with a double-deck structure of self-optimizing and fuzzy control is developed and presented in this paper. This control strategy uses only input and output signals.

Table 1. Mamdani fuzzy control rule.

e \ Δe	NG	NM	NP	ZE	PP	PM	PG
NG	PG	PG	PG	PG	PM	PP	ZE
NM	PG	PG	PM	PM	PP	ZE	ZE
NP	PG	PM	PM	PP	ZE	ZE	NP
ZE	PM	PP	PP	ZE	NP	NP	NM
PP	PP	ZE	ZE	NP	NM	NM	NG
PM	ZE	ZE	NP	NM	NM	NG	NG
PG	ZE	NP	NM	NG	NG	NG	NG

3. Self-Adjusting Fuzzy Logic Controller

A simple fuzzy controller has many shortcomings, such as difficult selection of good fuzzy parameters, so there are many methods to improve its performance [7 - 8]. Here the fuzzy controller had some improvements, by developing a method of adjusting the quantification and proportion factors. The selection of these factors makes a big influence on the static and dynamic performances of the controller. The following procedure is employed:

1. A bigger K_e will lead to a faster speed of the system reaction, but a bigger K_e will also make the system have a bigger overshoot. A smaller K_e will make the inverse influence. Furthermore, K_e is also related to the steady state error of the system: the bigger the K_e is, the smaller the steady state error and the control dead zone are.
2. A bigger K_{ec} will cause the system transition time to be longer, and the systems reaction becomes blunt; while a small K_{ec} will give the system a higher overshoot and surge. Another characteristic of K_{ec} is that its value can be selected in a wide range. In other words, the system is not much sensitive to the change to K_{ec} .
3. In the rising stage and steady period of the system response, K_u has different influences. In the rising period, a big K_u can make the system have a quick rising, but also causes overshoot easily; while a small K_u will make the system reaction become slower. In a steady period, a bigger K_u will cause a bigger surge. There are many kinds of schemes to improve selection of K_e , K_{ec} and K_u . But all of them follow the same logic: when the error is big, the aim of the system control is mainly to rapidly reduce the error and speed up the dynamic process. A small K_e , a small K_{ec} , and a bigger K_u are sufficient for this purpose. When the error and the change of error are small, and the system is close to the steady state, we need a fine control. A bigger K_e and K_{ec} is needed to enhance the system sensitivity and reduce the control dead zone. Furthermore, reducing K_u will make the system have a small overshoot and a small steady state error.

A conclusion can be draw from this discussion that the change trend of K_e , K_{ec} and K_u is not the same for each of them, and sometimes the control effects are opposite. On the basis that K_{ec} has less influence on the system, we can get the strategy of parameter adjustment, that is, K_{ec} is adjusted off-line and manually; K_e and K_u are automatically adjusted on-line. For convenience, K_e and K_u are reciprocal to each other. Let

$$K_e = K_{e0} * N; K_u = K_{u0}/N$$

Here, K_{e0} and K_{u0} are the initial values set up manually; N is the adjustment factor.

The rule to correct N is shown in Table 2, where input variables are error and change of error, and the output variable is N . These fuzzy variables have 5 values as follows:

Table 2. Modified rules for N

e \ Δe	NG	NP	ZE	PP	PG
NG	CB	CS	OK	CS	CB
NP	CS	OK	AS	OK	CS
ZE	OK	AS	AB	AS	OK
PP	CS	AS	OK	AS	CS
PG	CB	CS	OK	CS	CB

Error and change of error have values NB: (Negative Big); NS: (Negative Small); ZR: (Zero); PS: (Positive Small); PB: (Positive Big).

N has values AB (Amplify Big); AS (Amplify Small); OK (No changing); CS (Contract Small); CB (Contract Big). Let the quantification factors of error and change of error be: $K_{0e} = 1/4$, $K_{0ec} = 1/8$; thus, their value domains are: $E, E_c \in \{4, 3, 2, 1, 0, 1, 2, 3, 4\}$; the range of N is: $N \in \{0.125, 0.25, 0.5, 1, 2, 4, 8\}$. Here we choose a small quantification factor that makes the error and change of error with a narrow value region. This is because the change of N does not need to be adjusted tenuously. Fewer values of error and change of error will make the query table simple. Fuzzy sets of error E, change of error EC, and factor N are shown in Figure 5 - 6.

The structure of a fuzzy controller in the control loop are shown in Figure 1, where F (Fuzzification), KB (Knowledge Base), IM (Inference Machine) and D (Defuzzification). For this SISO (single input, single output) system, a fuzzy controller with two dimensions is suitable, and its input variables are error E and the change of error E_c and the output variable of the controller is the set point to control the speed of the scale [9].

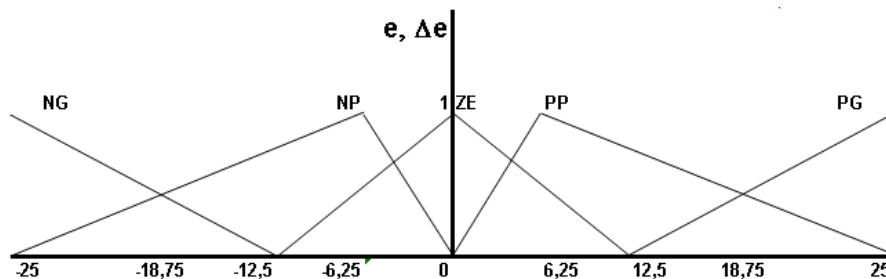

Figure 5. Membership of the Error and Change of Error.

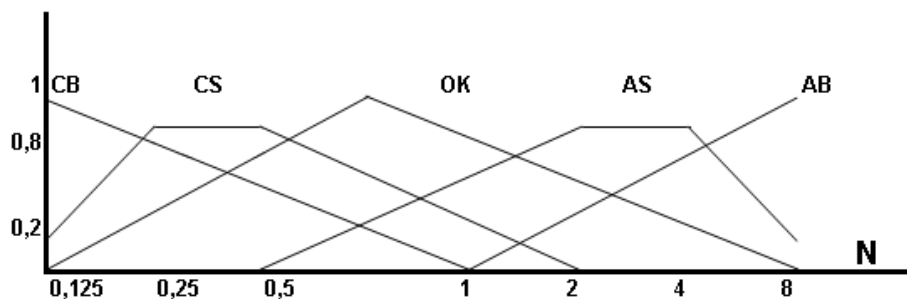

Figure 6. Membership of the Factor N.

4. Results

The controller designed above was put into service and starts the self-tuning parameters. The results for the alumina feeding show that the effect is very satisfying. The summary of the test can be seen in Figure 7.

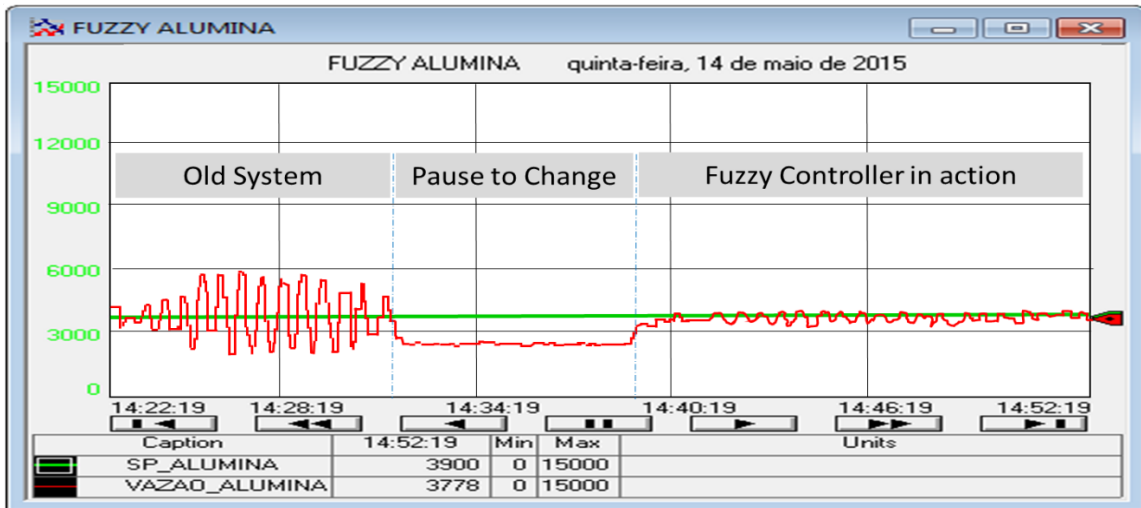

Figure 7. Signal controller behavior before and after the Fuzzy Controller.

In a second moment the alumina fuzzy controller already presents an excellent performance in terms of overshoot limitation and sensitivity to variation in process parameters.



Figure 8. Alumina Fuzzy Controller performance.

The same fuzzy controller approach is already in place for Crust feeding and the performance of the controller can be seen in the Figure 9.



Figure 9. Fuzzy Controller performance for Crust feeding.

The Fuzzy controller maps multiple operating regions, allowing multiple options of recipes and production rates.



Figure 10. Fuzzy Controller response for several production rates.

The alumina variability in ACM recipe before and after the implementation of the fuzzy controllers can be seen in the Figure (11 – 12). With the fuzzy controller implementation, the alumina variability has reduced around 50 %.

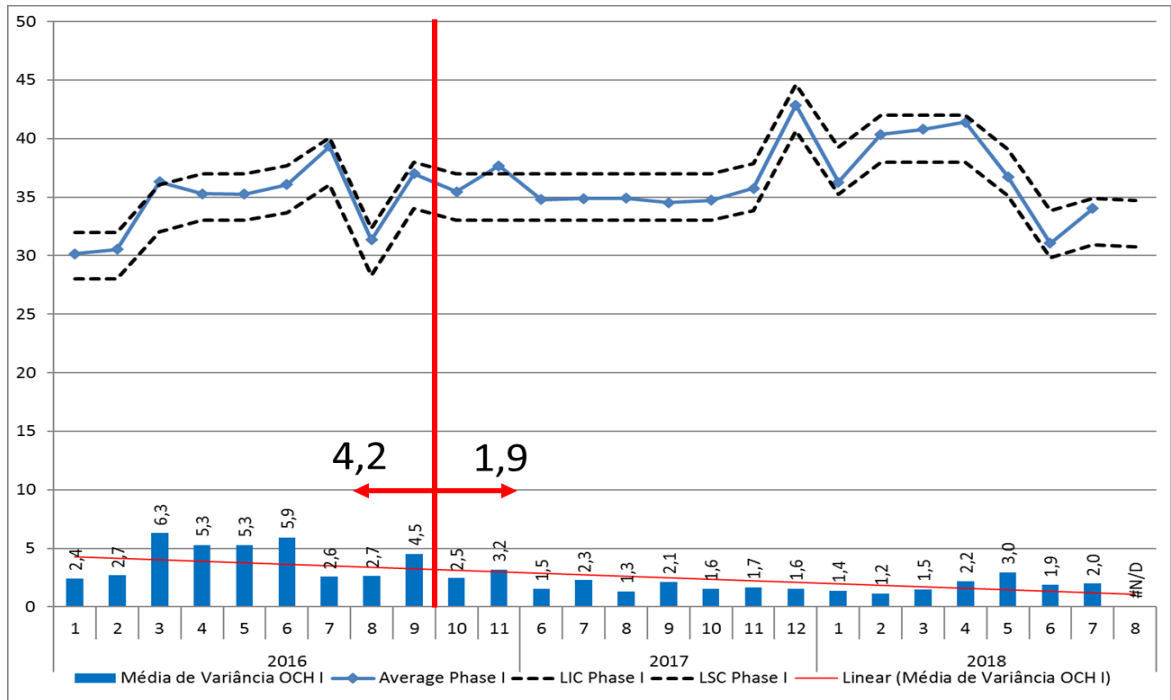

Figure 11. Fuzzy Controller and alumina variance at the ACM Plant 1.

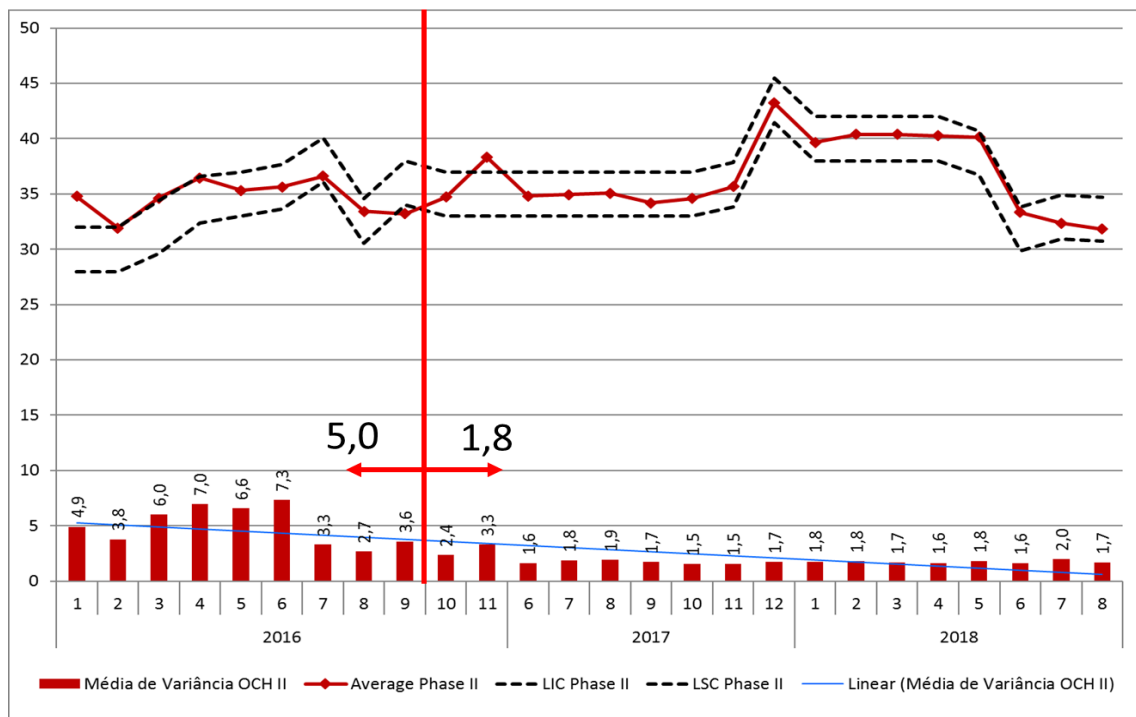

Figure 12. Fuzzy Controller and alumina variance at the ACM Plant 2

5. Conclusion

The Fuzzy Controller provided improvement in the performance in terms of overshoot limitation and sensitivity to parameters variations. The Fuzzy Controller mapped various regions of operation, resulting in effective small-signal and large-signal operation. Another important characteristic of these fuzzy controllers is the capability to check its own performance and flag some warning. The performance can be jeopardized by electric and mechanic issues.

With the Adaptive Fuzzy Controller, the ACM Plants get to produce within the client specifications.

6. References

1. Siegfried Wilkening, Pierre Reny and Brian Murphy, Anode cover material and bath level control, *Light Metals*, 2005, 367-372.
2. G. M. Abdelnour, Design of a fuzzy controller using input and output mapping factors, *IEEE Trans. Syst., Man, Cybern*, Vol 19, 1991, 952-960.
3. Li-Xin Wang, *A course in fuzzy system and control*, Prentice Hall PTR, Upper Saddle River, NJ, 1997, 20-104.
4. C. H. Chen (Editor), *Fuzzy logic and neural network handbook*, McGraw-Hill, Inc. 1996.
5. Edson Cruz, fuzzy control in green anode plant mixers, *Light Metals* 2004, 517-521.
6. P. J. King and E. H. Mamdani, The application of fuzzy control systems to industrial processes, *Automatica*, Vol 13, 1977, 235-242.
7. P. Martin Larsen, Industrial application of fuzzy logic control, *Int. J. Man-Machine Studies*, 1980, 3-10.
8. Lixin Jia and Xinzhong Li, Self-optimization combined with fuzzy logic control for ball mill, *IJCSS*, Vol.1, No.2, 2000, 231-239.
9. Edson Cruz, Adaptive fuzzy controller for ball mill in anode plant, *Light Metals* 2012, 1143-1145.